

NF EN 10216-5

mars 2005

AFNOR
Association Française
de Normalisation

www.afnor.fr

Ce document est à usage exclusif et non collectif des clients AFNOR SAGAWEB. Toute mise en réseau, reproduction et rediffusion, sous quelque forme que ce soit, même partielle, sont strictement interdites.

This document is intended for the exclusive and non collective use of AFNOR SAGAWEB. (Standards on line) customers. All network exploitation, reproduction and re-dissemination, even partial, whatever the form (hardcopy or other media), is strictly prohibited.

SAGAWEB

Pour : EDF R&D EDF Branche Energies

le 22/2/2006 - 2:52

Toute reproduction ou représentation intégrale ou partielle, par quelque procédé que ce soit, des pages publiées dans le présent document, faite sans l'autorisation de l'éditeur est illicite et constitue une contrefaçon. Seules sont autorisées, d'une part, les reproductions strictement réservées à l'usage privé du copiste et non destinées à une utilisation collective et, d'autre part, les analyses et courtes citations justifiées par le caractère scientifique ou d'information de l'œuvre dans laquelle elles sont incorporées (Loi du 1^{er} juillet 1992 – art. L 122-4 et L 122-5, et Code Pénal art. 425).

Diffusé par

AFNOR

European standard

NF EN 10216-5

March 2005

French standard

Classification index: **A 49-200-5****ICS: 23.040.10; 77.140.75****Seamless steel tubes for pressure purposes**

Technical delivery conditions

Part 5: Stainless steel tubes

F : Tubes sans soudure en acier pour service sous pression —
Conditions techniques de livraison — Partie 5 : Tubes en aciers inoxydables
D : Nahtlose Stahlrohre für Druckbeanspruchungen —
Technische Lieferbedingungen — Teil 5: Rohre aus nichtrostenden Stählen

French standard approved

by decision of the Director General of AFNOR on February 20, 2005 taking effect on March 20, 2005.

Replaces the approved standards NF A 49-117 dated September 1985, NF A 49-217 dated October 1987 and NF A 49-218 dated April 1979.

Correspondence The European standard EN 10216-5:2004 has the status of French standard.**Analysis**

This document specifies the technical delivery conditions, according to two test categories, for circular seamless austeno-ferritic and austenitic stainless steel (including creep-resistant steel) tubes, used for pressure purposes and for applications with corrosion resistance, at ambient, high or low temperature.

Descriptors

Technical International Thesaurus: steel tubes, seamless tubes, stainless steels, austenitic steels, designation, delivery condition, manufacturing, chemical composition, dimensions, dimensional tolerances, corrosion resistance, appearance, tests, acceptance testing, marking.

Modifications With respect to documents replaced, adoption of the European standard.**Corrections**

National foreword*References to French standards*

The correspondence between the standards figuring in the clause "Normative references" and the identical French standards is as follows:

EN 10002-1	: NF EN 10002-1 (classification index: A 03-001)
EN 10002-5	: NF EN 10002-5 (classification index: A 03-005)
EN 10020	: NF EN 10020 (classification index: A 02-025)
EN 10021	: NF EN 10021 (classification index: A 00-100)
EN 10027-1	: NF EN 10027-1 (classification index: A 02-005-1)
EN 10027-2	: NF EN 10027-2 (classification index: A 02-005-2)
EN 10028-7	: NF EN 10028-7 (classification index: A 36-205-7)
EN 10045-1	: NF EN 10045-1 (classification index: A 03-011)
EN 10052	: NF EN 10052 (classification index: A 02-010)
EN 10088-1	: NF EN 10088-1 (classification index: A 35-572)
EN 10204	: NF EN 10204 (classification index: A 00-001)
EN 10233	: NF EN ISO 8492 (classification index: A 03-092)
EN 10234	: NF EN ISO 8493 (classification index: A 03-093)
EN 10236	: NF EN ISO 8495 (classification index: A 03-095)
EN 10237	: NF EN ISO 8496 (classification index: A 03-096)
EN 10246-2	: NF EN 10246-2 (classification index: A 49-875-2)
EN 10246-6	: NF EN 10246-6 (classification index: A 49-875-6)
EN 10246-7	: NF EN 10246-7 (classification index: A 49-875-7)
EN 10246-17	: NF EN 10246-17 (classification index: A 49-875-17)
EN 10256	: NF EN 10256 (classification index: A 49-876)
EN 10168	: NF EN 10168 (classification index: A 03-116)
EN 10266	: NF EN 10266 (classification index: A 49-002)
EN ISO 377	: NF EN ISO 377 (classification index: A 03-112)
EN ISO 643	: NF EN ISO 643 (classification index: A 04-102)
EN ISO 1127	: NF EN ISO 1127 (classification index: A 49-950)
EN ISO 2566-2	: NF EN ISO 2566-2 (classification index: A 03-175)
EN ISO 3651-2	: NF EN ISO 3651-2 (classification index: A 05-159)
EN ISO 14284	: NF EN ISO 14284 (classification index: A 06-375)
CR 10260	: FD CR 10260 (classification index: A 02-005-3)
CR 10261	: FD CR 10261 (classification index: A 30-002)

EUROPEAN STANDARD

EN 10216-5

NORME EUROPÉENNE

EUROPÄISCHE NORM

September 2004

ICS 23.040.10; 77.140.75

English version

Seamless steel tubes for pressure purposes - Technical delivery conditions - Part 5: Stainless steel tubes

Tubes en acier sans soudure pour service sous pression -
Conditions techniques de livraison - Partie 5: Tubes en
aciers inoxydables

Nahtlose Stahlrohre für Druckbeanspruchungen -
Technische Lieferbedingungen - Teil 5: Rohre aus
nichtrostenden Stählen

This European Standard was approved by CEN on 3 March 2004.

CEN members are bound to comply with the CEN/CENELEC Internal Regulations which stipulate the conditions for giving this European Standard the status of a national standard without any alteration. Up-to-date lists and bibliographical references concerning such national standards may be obtained on application to the Central Secretariat or to any CEN member.

This European Standard exists in three official versions (English, French, German). A version in any other language made by translation under the responsibility of a CEN member into its own language and notified to the Central Secretariat has the same status as the official versions.

CEN members are the national standards bodies of Austria, Belgium, Cyprus, Czech Republic, Denmark, Estonia, Finland, France, Germany, Greece, Hungary, Iceland, Ireland, Italy, Latvia, Lithuania, Luxembourg, Malta, Netherlands, Norway, Poland, Portugal, Slovakia, Slovenia, Spain, Sweden, Switzerland and United Kingdom.



EUROPEAN COMMITTEE FOR STANDARDIZATION
COMITÉ EUROPÉEN DE NORMALISATION
EUROPÄISCHES KOMITEE FÜR NORMUNG

Management Centre: rue de Stassart, 36 B-1050 Brussels

EN 10216-5:2004 (E)

Contents

	page
Foreword.....	4
1 Scope	5
2 Normative references	5
3 Terms and definitions.....	6
4 Symbols	7
5 Classification and designation	7
5.1 Classification.....	7
5.2 Designation.....	7
6 Information to be supplied by the purchaser.....	7
6.1 Mandatory information	7
6.2 Options.....	7
6.3 Examples of an order	9
7 Manufacturing process	9
7.1 Steelmaking process	9
7.2 Tube manufacture and delivery conditions	9
8 Requirements	10
8.1 General.....	10
8.2 Chemical composition.....	10
8.3 Mechanical properties	17
8.4 Corrosion resistance	25
8.5 Appearance and soundness	25
8.6 Straightness	26
8.7 Preparation of ends	26
8.8 Dimensions, masses and tolerances	27
9 Inspection	28
9.1 Type of inspection	28
9.2 Inspection documents	28
9.3 Summary of inspection and testing.....	29
10 Sampling	29
10.1 Test unit	29
10.2 Preparation of samples and test pieces	30
11 Test methods.....	32
11.1 Chemical analysis	32
11.2 Tensile test	32
11.3 Technological tests	33
11.4 Impact test	34
11.5 Intergranular corrosion test.....	35
11.6 Leak tightness test	35
11.7 Dimensional inspection.....	35
11.8 Visual examination	36
11.9 Non-destructive testing.....	36
11.10 Material identification	36
11.11 Retests, sorting and reprocessing.....	36
12 Marking	36
12.1 Marking to be applied	36
12.2 Additional marking	37
13 Handling and packaging	37
Annex A (informative) Reference data of strength values for creep rupture of austenitic steels in the solution annealed condition	38

Annex ZA (informative) Clauses of this part of EN 10216 addressing essential safety requirements of the EU Directive 97/23/EC	44
Bibliography	45

EN 10216-5:2004 (E)

Foreword

This document (EN 10216-5:2004) has been prepared by Technical Committee ECISS/TC 29 "Steel tubes and fittings for steel tubes", the secretariat of which is held by UNI.

This European Standard shall be given the status of a national standard, either by publication of an identical text or by endorsement, at the latest by March 2005, and conflicting national standards shall be withdrawn at the latest by March 2005.

This document has been prepared under a mandate given to CEN by the European Commission and the European Free Trade Association, and supports essential requirements of the EU Directive 97/23/EC.

For relationship with the EU Directive 97/23/EC, see informative Annex ZA, which is an integral part of this document.

Other parts of EN 10216 are:

- *Part 1: Non-alloy steel tubes with specified room temperature properties;*
- *Part 2: Non-alloy and alloy steel tubes with specified elevated temperature properties;*
- *Part 3: Alloy fine grain steel tubes;*
- *Part 4: Non-alloy and alloy steel tubes with specified low temperature properties.*

Another European Standard series covering tubes for pressure purposes is:

- EN 10217: *Welded steel tubes for pressure purposes – Technical delivery conditions.*

According to the CEN/CENELEC Internal Regulations, the national standards organizations of the following countries are bound to implement this European Standard : Austria, Belgium, Cyprus, Czech Republic, Denmark, Estonia, Finland, France, Germany, Greece, Hungary, Iceland, Ireland, Italy, Latvia, Lithuania, Luxembourg, Malta, Netherlands, Norway, Poland, Portugal, Slovakia, Slovenia, Spain, Sweden, Switzerland and United Kingdom.

1 Scope

This document specifies the technical delivery conditions in two test categories for seamless tubes of circular cross section made of austenitic (including creep resisting steel) and austenitic-ferritic stainless steel which are applied for pressure and corrosion resisting purposes at room temperature, at low temperatures or at elevated temperatures.

2 Normative references

The following referenced documents are indispensable for the application of this document. For dated references, only the edition cited applies. For undated references, the latest edition of the referenced document (including any amendments) applies.

The requirements of this part of EN 10216 rule when they differ from those in the standards and documents referred to below:

EN 10002-1, *Metallic materials - Tensile testing - Part 1: Method of test at ambient temperature.*

EN 10002-5, *Metallic materials - Tensile testing - Part 5: Method of test at elevated temperatures.*

EN 10020:2000, *Definition and classification of grades of steel.*

EN 10021:1993, *General technical delivery conditions for steel and iron products.*

EN 10027-1, *Designation systems for steels - Part 1: Steel names, principal symbols.*

EN 10027-2, *Designation systems for steels - Part 2: Numerical systems.*

EN 10028-7, *Flat products made of steels for pressure purposes - Part 7: Stainless steels.*

EN 10045-1, *Metallic materials - Charpy impact test - Part 1: Test method.*

EN 10052:1993, *Vocabulary of heat treatment terms for ferrous products.*

EN 10088-1, *Stainless steels - Part 1: List of stainless steels.*

EN 10204, *Metallic products - Types of inspection documents.*

EN 10233, *Metallic materials - Tubes - Flattening test.*

EN 10234, *Metallic materials - Tubes - Drift expanding test.*

EN 10236, *Metallic materials - Tubes - Ring expanding test.*

EN 10237, *Metallic materials - Tubes - Ring tensile test.*

EN 10246-2, *Non-destructive testing of steel tubes - Part 2: Automatic eddy current testing of seamless and welded (except submerged arc-welded) austenitic and ferritic-austenitic steel tubes for verification of hydraulic leak tightness.*

EN 10246-6, *Non-destructive testing of steel tubes - Part 6: Automatic full peripheral ultrasonic testing of seamless steel tubes for the detection of transverse imperfections.*

EN 10246-7, *Non-destructive testing of steel tubes - Part 7: Automatic full peripheral ultrasonic testing of seamless and welded (except submerged arc welded) steel tubes for the detection of longitudinal imperfections.*

EN 10246-17, *Non-destructive testing of steel tubes - Part 17: Ultrasonic testing of tube ends of seamless and welded steel tubes for detection of laminar imperfections.*

EN 10216-5:2004 (E)

EN 10256, *Non-destructive testing of steel tubes - Qualification and competence of level 1 and level 2 non-destructive testing personnel.*

EN 10168, *Steel products - Inspection documents - List of information and description.*

EN 10266:2003, *Steel tubes, fittings and structural hollow sections - Symbols and definitions of terms for use in product standards.*

EN ISO 377, *Steel and steel products - Location and preparation of samples and test pieces for mechanical testing (ISO 377:1997).*

EN ISO 643, *Steels - Micrographic determination of the apparent grain size (ISO 643:2003)*

EN ISO 1127, *Stainless steel tubes - Dimensions, tolerances and conventional masses per unit length (ISO 1127:1992).*

EN ISO 2566-2, *Steel - Conversion of elongation values - Part 2: Austenitic steels (ISO 2566-2:1984).*

EN ISO 3651-2, *Determination of resistance to intergranular corrosion of stainless steels - Part 2: Ferritic, austenitic and ferritic-austenitic (duplex) stainless steels - Corrosion test in media containing sulfuric acid (ISO 3651.2:1998).*

EN ISO 14284, *Steel and iron - Sampling and preparation of samples for the determination of the chemical composition (ISO 14284:1996).*

CR 10260, *Designation systems for steel - Additional symbols.*

CR 10261, *ECISS Information Circular 11 - Iron and steel - Review of available methods of chemical analysis.*

3 Terms and definitions

For the purposes of this document, the terms and definitions given in EN 10020:2000, EN 10021:1993, EN 10052:1993 and EN 10266:2003 together with the following apply.

3.1
test category
classification that indicates the extent and level of inspection and testing

3.2
employer
organization for which a person works on a regular basis

NOTE The employer may be either the tube manufacturer or supplier or a third party organization providing Non-Destructive Testing (NDT) services.

4 Symbols

For the purposes of this document, the symbols given in EN 10266 and the following apply:

- TC test category

NOTE See also Table 1 for symbols of the delivery condition.

5 Classification and designation

5.1 Classification

According to the classification system in EN 10020, the steel grades are classified as:

- austenitic steels (corrosion resisting or creep resisting steels);
- austenitic-ferritic steels.

For more details see EN 10088-1.

5.2 Designation

For the tubes covered by this part of EN 10216 the steel designation consists of:

- number of this part of EN 10216 (EN 10216-5);

plus either:

- steel name in accordance with EN 10027-1 and CR 10260;

or:

- steel number allocated in accordance with EN 10027-2.

6 Information to be supplied by the purchaser

6.1 Mandatory information

The following information shall be supplied by the purchaser at the time of enquiry and order:

- quantity (mass or total length or number);
- term "tube";
- dimensions (outside diameter D and wall thickness T) (see 8.8.1);
- designation of the steel grade according to this part of EN 10216 (see 5.2);
- test category (see 9.3).

6.2 Options

A number of options are specified in this part of EN 10216 and these are listed below. In the event that the purchaser does not indicate a wish to implement any of these options at the time of enquiry and order, the tube shall be supplied in accordance with the basic specification (see 6.1).

EN 10216-5:2004 (E)

1. Information about steelmaking process (see 7.1).
2. Delivery condition (see 7.2.4).
3. Specified range for sulphur content (see Table 2, footnote b).
4. Product analysis (see 8.2.2).
5. Additional mechanical tests on samples which have undergone a different or additional heat treatment (see 8.3.1).
6. Impact test at room temperature (see 8.3.1).
7. Agreed mechanical properties at room temperature for austenitic corrosion resisting steel tubes with wall thicknesses greater than 60 mm (see Table 6, footnote a).
8. Agreed mechanical properties at room temperature for austenitic creep resisting steel tubes with wall thicknesses greater than 50 mm (see Table 7, footnote a).
9. Verification of proof strength $R_{p0,2}$ or $R_{p1,0}$ at elevated temperatures (see 8.3.2.1).
10. Agreed proof strength values at elevated temperatures for austenitic corrosion resisting steel tubes with wall thicknesses greater than 60 mm (see Table 9, footnote a).
11. Impact test at low temperature (see 8.3.3).
12. Intergranular corrosion test (see 8.4).
13. Selection of leak-tightness test method (see 8.5.2.1).
14. Non-destructive testing for test category 2 tubes with specified outside diameter less than or equal to 101,6 mm and specified wall thickness less than or equal to 5,6 mm for detection of longitudinal imperfections (see 8.5.2.2).
15. Non-destructive testing for test category 2 tubes for detection of transverse imperfections (see 8.5.2.2).
16. Non-destructive testing for test category 2 tubes with specified wall thickness greater than 40 mm for detection of laminar imperfections at tube ends (see 8.5.2.2).
17. Special ends preparation (see 8.7).
18. Exact lengths (see 8.8.3).
19. Sized tube ends for tube of $D > 219,1$ mm (see Table 12).
20. Tolerance classes D 4 and T 4 for tubes ordered cold finished (see Table 13).
21. Type of inspection document other than the standard document (see 9.2.1).
22. Test pressure for hydrostatic leak-tightness test (see 11.6.1).
23. Wall thickness measurement away from the ends (see 11.7).
24. Additional marking (see 12.2).
25. Special protection (see 13).

6.3 Examples of an order

6.3.1 Example 1

2 000 m of hot finished descaled seamless tube with an outside diameter of 168,3 mm, a wall thickness of 4,5 mm, in accordance with this part of EN 10216, tolerance classes D 2 and T 2, made of steel grade X2CrNi19-11, to test category 1, with a 3.1.B inspection certificate in accordance with EN 10204:

2 000 m - HFD Tube – 168,3 X 4,5 - EN 10216-5 - X2CrNi19-11 - TC 1

6.3.2 Example 2

300 m of cold finished descaled seamless tube with an outside diameter of 42,4 mm, a wall thickness of 2,6 mm, in accordance with this part EN 10216, tolerance classes D 3 and T 3, made of steel grade 1.4301, to test category 2, with intergranular corrosion test (EN ISO 3651-2, method A), verification of proof strength at 300 °C, non-destructive testing for detection of longitudinal and transverse imperfections, with a 3.2 inspection certificate in accordance with EN 10204:

300 m - CFD Tube – 42,4 X 2,6 - EN 10216-5 - 1.4301 – TC 2 - Option 9: 300 °C – Option 12: A – Option 14 - Option 15 - Option 21: 3.2

7 Manufacturing process

7.1 Steelmaking process

The steelmaking process is at the discretion of the manufacturer, but see option 1.

Option 1: *The purchaser shall be informed about the steelmaking process used. The process shall be reported in the inspection document.*

7.2 Tube manufacture and delivery conditions

7.2.1 All NDT activities shall be carried out by qualified and competent level 1, 2 and/or 3 personnel authorised to operate by the employer.

The qualification shall be in accordance with EN 10256 or, at least, an equivalent to it.

It is recommended that the level 3 personnel be certified in accordance to EN 473 or, at least an equivalent to it.

The operating authorisation issued by the employer shall be in accordance with a written procedure.

NDT operations shall be authorised by a level 3 NDT individual approved by the employer.

NOTE The definition of level 1, 2 and 3 can be found in appropriate standards, e.g. EN 473 and EN 10256.

7.2.2 The tubes shall be manufactured by a seamless process, and may be hot finished or cold finished. The terms “ hot finished “ and “ cold finished “ apply to the condition of the tube before it is heat treated in accordance with 7.2.3.

The process of manufacture is left to the discretion of the manufacturer, but see option 2.

EN 10216-5:2004 (E)

7.2.3 The tubes shall be supplied in the solution annealed condition over their full length in either:

- reference heat treatment conditions;
- solution annealed conditions obtained directly by extrusion and subsequent cooling provided the mechanical properties, corrosion resistance and other properties are in accordance with this part of EN 10216. All specified mechanical properties shall be met even after a subsequent reference heat treatment.

Solution treatment shall consist of heating the tubes uniformly to a temperature within the range given for the steel grade concerned in Tables 6, 7 and 8 and cooling rapidly.

7.2.4 The types of delivery condition of the tubes are given in Table 1.

Unless option 2 is specified, the type of delivery condition is at the discretion of the manufacturer.

Option 2: *The delivery condition is specified by the purchaser.*

Table 1 — Delivery conditions ^a

Symbol ^b	Type of delivery condition	Surface condition
HFD	Hot finished heat treated, descaled	Metallically clean
CFD	Cold finished heat treated, descaled	Metallically clean
CFA	Cold finished bright annealed	Metallically bright
CFG	Cold finished heat treated, ground	Metallically bright-ground, the type and degree of roughness shall be agreed at the time of enquiry and order ^c
CFP	Cold finished heat treated, polished	Metallically bright-polished, the type and degree of roughness shall be agreed at the time of enquiry and order ^c

^a Combinations of the different conditions may be agreed at the time of enquiry and order.

^b The symbols are abbreviations for type of condition. Example: CFD = Cold Finished Descaled.

^c The enquiry and the order shall indicate whether the roughness requirement applies on the internal or external tube surface, or internal and external.

8 Requirements

8.1 General

When supplied in a delivery condition indicated in 7.2.4 and inspected in accordance with clauses 9, 10 and 11, the tubes shall conform to the requirements of this part of EN 10216.

In addition, the general technical delivery requirements specified in EN 10021 shall apply.

8.2 Chemical composition

8.2.1 Cast analysis

The cast analysis reported by the steel manufacturer shall apply and conform to the requirements of Tables 2 or 3 for austenitic steels and of Table 4 for austenitic-ferritic steels.

Option 3: *(see Table 2).*

NOTE When welding tubes produced in accordance with this part of EN 10216, account should be taken to the fact that the behaviour of the steel during and after welding is dependent not only on the steel, but also on the applied heat treatment and the conditions of preparing for and carrying out the welding.

8.2.2 Product analysis

Option 4: Product analysis for the tubes shall be supplied.

Table 5 specifies the permissible deviation of the product analysis from the specified limits on cast analysis given in Tables 2, 3 and 4.

Table 2 — Chemical composition (cast analysis) ^a of austenitic corrosion resisting steels, in % by mass (continued)

Steel grade		C max	Si	Mn	P max	S max	N	Cr	Cu	Mo	Nb	Ni	Ti	Others
Steel name	Steel number													
X2CrNi18-9	1.4307	0,030	≤ 1,00	≤ 2,00	0,040	0,015 ^b	≤ 0,11	17,50 to 19,50	—	—	—	8,00 to 10,00 ^c	—	—
X2CrNi19-11	1.4306	0,030	≤ 1,00	≤ 2,00	0,040	0,015 ^b	≤ 0,11	18,00 to 20,00	—	—	—	10,00 to 12,00 ^d	—	—
X2CrNi18-10	1.4311	0,030	≤ 1,00	≤ 2,00	0,040	0,015	0,12 to 0,22	17,00 to 19,50	—	—	—	8,50 to 11,50	—	—
X5CrNi18-10	1.4301	0,07	≤ 1,00	≤ 2,00	0,040	0,015 ^b	≤ 0,11	17,00 to 19,50	—	—	—	8,00 to 10,50	—	—
X6CrNiTi18-10	1.4541	0,08	≤ 1,00	≤ 2,00	0,040	0,015	—	17,00 to 19,00	—	—	—	9,00 to 12,00 ^d	5xC to 0,70	—
X6CrNiNb18-10	1.4550	0,08	≤ 1,00	≤ 2,00	0,040	0,015	—	17,00 to 19,00	—	—	10xC to 1,00	9,00 to 12,00 ^d	—	—
X1CrNi25-21	1.4335	0,020	≤ 0,25	≤ 2,00	0,025	0,010	≤ 0,11	24,00 to 26,00	—	≤ 0,20	—	20,00 to 22,00	—	—
X2CrNiMo17-12-2	1.4404	0,030	≤ 1,00	≤ 2,00	0,040	0,015 ^b	≤ 0,11	16,50 to 18,50	—	2,00 to 2,50	—	10,00 to 13,00 ^e	—	—
X5CrNiMo17-12-2	1.4401	0,07	≤ 1,00	≤ 2,00	0,040	0,015 ^b	≤ 0,11	16,50 to 18,50	—	2,00 to 2,50	—	10,00 to 13,00	—	—
X1CrNiMoN25-22-2	1.4466	0,020	≤ 0,70	≤ 2,00	0,025	0,010	0,10 to 0,16	24,00 to 26,00	—	2,00 to 2,50	—	21,00 to 23,00	—	—
X6CrNiMoTi17-12-2	1.4571	0,08	≤ 1,00	≤ 2,00	0,040	0,015 ^b	—	16,50 to 18,50	—	2,00 to 2,50	—	10,50 to 13,50 ^c	5xC to 0,70	—
X6CrNiMoNb17-12-2	1.4580	0,08	≤ 1,00	≤ 2,00	0,040	0,015	—	16,50 to 18,50	—	2,00 to 2,50	10xC to 1,00	10,50 to 13,50	—	—
X2CrNiMoN17-13-3	1.4429	0,030	≤ 1,00	≤ 2,00	0,040	0,015	0,12 to 0,22	16,50 to 18,50	—	2,50 to 3,00	—	11,00 to 14,00 ^d	—	—
X3CrNiMo17-13-3	1.4436	0,05	≤ 1,00	≤ 2,00	0,040	0,015 ^b	≤ 0,11	16,50 to 18,50	—	2,50 to 3,00	—	10,50 to 13,00 ^d	—	—
X2CrNiMo18-14-3	1.4435	0,030	≤ 1,00	≤ 2,00	0,040	0,015 ^b	≤ 0,11	17,00 to 19,00	—	2,50 to 3,00	—	12,50 to 15,00	—	—
X2CrNiMoN17-13-5	1.4439	0,030	≤ 1,00	≤ 2,00	0,040	0,015	0,12 to 0,22	16,50 to 18,50	—	4,00 to 5,00	—	12,50 to 14,50	—	—

Steel grade		C max	Si	Mn	P max	S max	N	Cr	Cu	Mo	Nb	Ni	Ti	Others
Steel name	Steel number													
X1NiCrMoCu31-27-4	1.4563	0,020	≤ 0,70	≤ 2,00	0,030	0,010	≤ 0,11	26,00 to 28,00	0,70 to 1,50	3,00 to 4,00	–	30,00 to 32,00	–	–
X1NiCrMoCu25-20-5	1.4539	0,020	≤ 0,70	≤ 2,00	0,030	0,010	≤ 0,15	19,00 to 21,00	1,20 to 2,00	4,00 to 5,00	–	24,00 to 26,00	–	–
X1CrNiMoCuN20-18-7	1.4547	0,020	≤ 0,70	≤ 1,00	0,030	0,010	0,18 to 0,25	19,50 to 20,50	0,50 to 1,00	6,00 to 7,00	–	17,50 to 18,50	–	–
X1NiCrMoCuN25-20-7	1.4529	0,020	≤ 0,50	≤ 1,00	0,030	0,010	0,15 to 0,25	19,00 to 21,00	0,50 to 1,50	6,00 to 7,00	–	24,00 to 26,00	–	–
X2NiCrAlTi32-20	1.4558	0,030	≤ 0,70	≤ 1,00	0,020	0,015	–	20,00 to 23,00	–	–	–	32,00 to 35,00	8X(C+N) to 0,60	Al: 0,15 to 0,45

^a Elements not listed in this table shall not be intentionally added to the steel without the agreement of the purchaser except for finishing the cast. All appropriate precautions are to be taken to avoid the addition of such elements from scrap and other materials used in production which would impair mechanical properties and the suitability of the steel.

^b For products to be machined a controlled sulphur content of 0,015 % to 0,030 % is permitted by agreement provided the resistance to corrosion is still satisfied for the intended purpose.

Option 3: A sulphur content of 0,015 % to 0,030 % is specified.

^c Where for special reasons, e.g. hot workability it is necessary to minimize the deltaferrite content, or with the aim of low permeability, the maximum nickel content may be increased by 0,50 %.

^d Where for special reasons, e.g. hot workability it is necessary to minimize the deltaferrite content, or with the aim of low permeability, the maximum nickel content may be increased by 1,00 %.

^e Where for special reasons, e.g. hot workability it is necessary to minimize the deltaferrite content, or with the aim of low permeability, the maximum nickel content may be increased by 1,50 %.

Table 3 - Chemical composition (cast analysis) ^a of austenitic creep resisting steels, in % by mass

Steel grade		C	Si	Mn	P max	S max	N	Cr	Cu	Mo	Nb	Ni	Ti	Others
Steel name	Steel number													
X6CrNi18-10	1.4948	0,04 to 0,08	≤ 1,00	≤ 2,00	0,035	0,015	≤ 0,11	17,00 to 19,00	-	-	-	8,00 to 11,00	-	-
X7CrNiTi18-10	1.4940	0,04 to 0,08	≤ 1,00	≤ 2,00	0,040	0,015	≤ 0,11	17,00 to 19,00	-	-	-	9,00 to 13,00	5x(C+N) to 0,80	
X7CrNiNb18-10	1.4912	0,04 to 0,10	≤ 1,00	≤ 2,00	0,040	0,015	≤ 0,11	17,00 to 19,00	-	-	10xC to 1,20	9,00 to 12,00		
X6CrNiTiB18-10	1.4941	0,04 to 0,08	≤ 1,00	≤ 2,00	0,035	0,015	-	17,00 to 19,00	-	-	-	9,00 to 12,00	5xC to 0,80	B: 0,0015 to 0,0050
X6CrNiMo17-13-2	1.4918	0,04 to 0,08	≤ 0,75	≤ 2,00	0,035	0,015	≤ 0,11	16,00 to 18,00	-	2,00 to 2,50		12,00 to 14,00	-	-
X5NiCrAlTi31-20 (+RA) ^b	1.4958(+RA)	0,03 to 0,08	≤ 0,70	≤ 1,50	0,015	0,010	-	19,00 to 22,00	≤ 0,50	-	≤ 0,10	30,00 to 32,50	0,20 to 0,50	Al: 0,20 to 0,50 Al+Ti: ≤ 0,70 Co: ≤ 0,5 Ni+Co = 30,0 to 32,5
X8NiCrAlTi32-21	1.4959	0,05 to 0,10	≤ 0,70	≤ 1,50	0,015	0,010	-	19,00 to 22,00	≤ 0,50	-	-	30,00 to 34,00	0,25 to 0,65	Al: 0,20 to 0,65
X3CrNiMoBN17-13-3	1.4910	≤ 0,04	≤ 0,75	≤ 2,00	0,035	0,015	0,10 to 0,18	16,00 to 18,00	-	2,00 to 3,00	-	12,00 to 14,00	-	B: 0,0015 to 0,0050
X8CrNiNb16-13	1.4961	0,04 to 0,10	0,30 to 0,60	≤ 1,50	0,035	0,015	-	15,00 to 17,00	-	-	10xC to 1,20	12,00 to 14,00	-	-
X8CrNiMoVNb16-13	1.4988	0,04 to 0,10	0,30 to 0,60	≤ 1,50	0,035	0,015	0,06 to 0,14	15,50 to 17,50	-	1,10 to 1,50	10xC to 1,20	12,50 to 14,50	-	V: 0,60 to 0,85
X8CrNiMoNb16-16	1.4981	0,04 to 0,10	0,30 to 0,60	≤ 1,50	0,035	0,015	-	15,50 to 17,50	-	1,60 to 2,00	10xC to 1,20 ^c	15,50 to 17,50	-	-
X10CrNiMoMnNbVB15-10-1	1.4982	0,06 to 0,15	0,20 to 1,00	5,50 to 7,00	0,035	0,015	-	14,00 to 16,00	-	0,80 to 1,20	0,75 to 1,25	9,00 to 11,00	-	V: 0,15 to 0,40 B 0,003 to 0,009

^a Elements not listed in this table shall not be intentionally added to the steel without the agreement of the purchaser except for finishing the cast. All appropriate precautions are to be taken to avoid the addition of such elements from scrap and other materials used in production which would impair mechanical properties and the suitability of the steel.

^b Recrystallizing annealed condition.

^c Including Ta.

Table 4 - Chemical composition (cast analysis) ^a of austenitic-ferritic steels, in % by mass

Steel grade		C max	Si	Mn	P max	S max	N	Cr	Cu	Mo	Ni	Others
Steel name	Steel number											
X2CrNiMoN22-5-3	1.4462	0,030	≤ 1,00	≤ 2,00	0,035	0,015	0,10 to 0,22	21,00 to 23,00	–	2,50 to 3,50	4,50 to 6,50	–
X2CrNiMoSi18-5-3	1.4424	0,030	1,40 to 2,00	1,20 to 2,00	0,035	0,015	0,05 to 0,10	18,00 to 19,00	–	2,50 to 3,00	4,50 to 5,20	–
X2CrNiN23-4 ^b	1.4362	0,030	≤ 1,00	≤ 2,00	0,035	0,015	0,05 to 0,20	22,00 to 24,00	0,10 to 0,60	0,10 to 0,60	3,50 to 5,50	–
X2CrNiMoN25-7-4 ^b	1.4410	0,030	≤ 1,00	≤ 2,00	0,035	0,015	0,20 to 0,35	24,00 to 26,00	–	3,00 to 4,50	6,00 to 8,00	–
X2CrNiMoCuN25-6-3	1.4507	0,030	≤ 0,70	≤ 2,00	0,035	0,015	0,15 to 0,30	24,00 to 26,00	1,00 to 2,50	2,70 to 4,00	5,50 to 7,50	–
X2CrNiMoCuWN25-7-4	1.4501	0,030	≤ 1,00	≤ 1,00	0,035	0,015	0,20 to 0,30	24,00 to 26,00	0,50 to 1,00	3,00 to 4,00	6,00 to 8,00	W: 0,50 to 1,00

^a Elements not listed in this table shall not be intentionally added to the steel without the agreement of the purchaser except for finishing the cast. All appropriate precautions are to be taken to avoid the addition of such elements from scrap and other materials used in production which would impair mechanical properties and the suitability of the steel.

^b Patented steel grade.

EN 10216-5:2004 (E)

Table 5 - Permissible deviations of the product analysis from specified limits on cast analysis given in Tables 2, 3 and 4

Element	Limiting value for the cast analysis according to Tables 2, 3 and 4 % by mass	Permissible deviation of the product analysis ^a % by mass
Carbon	≤ 0,030	+ 0,005
	> 0,030 ≤ 0,15	± 0,01
Silicon	≤ 2,00	± 0,05
Manganese	≤ 1,00	+ 0,03
	> 1,00 ≤ 2,00	± 0,04
	> 2,00 ≤ 7,00	± 0,10
Phosphorus	≤ 0,030	+ 0,003
	> 0,030 ≤ 0,040	+ 0,005
Sulphur	≤ 0,015	+ 0,003
	> 0,015 ≤ 0,030	+0,005
Nitrogen	≤ 0,35	± 0,01
Aluminium	≤ 0,65	± 0,10
Boron	≥0,001 5 ≤ 0,009 0	± 0,0003
Chromium	> 14,00 ≤ 20,00	± 0,20
	>20,00 ≤ 28,00	± 0,25
Cobalt	≤ 0,50	+ 0,10
Copper	≤ 1,00	± 0,07
	> 1,00 ≤ 2,50	± 0,10
Molybdenum	≤ 0,60	± 0,03
	> 0,60 ≤ 1,75	± 0,05
	> 1,75 ≤ 7,00	± 0,10
Niobium	≤ 1,25	± 0,05
Nickel	> 3,50 ≤ 5,00	± 0,07
	> 5,00 ≤ 10,00	± 0,10
	> 10,00 ≤ 20,00	± 0,15
	>20,00 ≤35,00	± 0,20
Titanium	≤ 0,80	± 0,05
Vanadium	≤ 0,85	± 0,03
Tungsten	≤ 1,00	± 0,05

^a If several product analyses are carried out on one cast, and the contents of an individual element determined lie outside the permissible range of the chemical composition specified for the cast analysis, then it is only allowed to exceed the permissible maximum value or to fall short of the permissible minimum value, but not both for one cast.

8.3 Mechanical properties

8.3.1 At room temperature

The mechanical properties of the tubes at room temperature shall conform to the relevant requirements in Tables 6, 7 and 8 and in clause 11.

If heat treatments different from, or additional to, the reference heat treatment are to be carried out after the delivery of the tubes, the purchaser may request, at the time of enquiry and order, additional mechanical tests on samples, that have been given heat treatments different from or additional to, those given in Tables 6, 7 and 8. The heat treatment of the samples and the mechanical properties to be obtained from tests on them shall be agreed between the purchaser and the manufacturer at the time of enquiry and order.

Option 5: *Additional mechanical tests on samples which have undergone a different or additional heat treatment shall be carried out.*

Option 6: *Impact test shall be carried out at room temperature (see Tables 6, 7 and 8).*

Option 7: (see Table 6, footnote a).

Option 8: (see Table 7, footnote a).

8.3.2 At elevated temperature

8.3.2.1 Proof strength

The minimum proof strength $R_{p0,2}$ and $R_{p1,0}$ values at elevated temperatures are specified in Tables 9, 10 and 11.

Option 9: *Proof strength $R_{p0,2}$ or $R_{p1,0}$ (for austenitic-ferritic steels in Table 11 only $R_{p0,2}$ apply) shall be verified. The test temperature shall be agreed at the time of enquiry and order.*

Option 10: (see Table 9, footnote a).

8.3.2.2 Creep rupture strength

Annex A gives mean values as preliminary data about creep rupture strength.

NOTE Steel grades not mentioned in Table A.1 are not intended for use in the creep range.

8.3.3 At low temperature

Impact energy values at specified low temperature shall conform to the requirements in Tables 6 and 8.

Option 11: *Impact test at low temperature shall be carried out.*

Table 6 - Mechanical properties for wall thicknesses up to 60 mm ^a of austenitic corrosion resisting steels in the solution annealed condition (+AT) and information about intergranular corrosion (continued) ^b

Steel grade		Tensile properties at room temperature ^c					Impact properties ^c			Reference heat treatment conditions		Resistance to intergranular corrosion	
		Proof strength		Tensile strength	Elongation		Minimum average absorbed energy KV J						
		$R_{p0,2}$ min	$R_{p1,0}$ min	R_m	A min (%)		at RT	at -196°C		Solution temperature ^d °C	Cooling in ^e	f	Method in EN ISO 3651-2
MPa	MPa	MPa	l	t	l	t	t						
X2CrNi18-9	1.4307	180	215	460 to 680	40	35	100	60	60	1 000 to 1 100	w, a	yes	A
X2CrNi19-11	1.4306	180	215	460 to 680	40	35	100	60	60	1 000 to 1 100	w, a	yes	A
X2CrNiN18-10	1.4311	270	305	550 to 760	35	30	100	60	60	1 000 to 1 100	w, a	yes	A
X5CrNi18-10	1.4301	195	230	500 to 700	40	35	100	60	60	1 000 to 1 100	w, a	yes ^g	A
X6CrNiTi18-10 (cold finish)	1.4541	200	235	500 to 730	35	30	100	60	60	1 020 to 1 120	w, a	yes	A
X6CrNiTi18-10 (hot finish)	1.4541	180	215	460 to 680	35	30	100	60	60	1 020 to 1 120	w, a	yes	A
X6CrNiNb18-10	1.4550	205	240	510 to 740	35	30	100	60	60	1 020 to 1 120	w, a	yes	A
X1CrNi25-21	1.4335	180	210	470 to 670	45	40	100	60	60	1 030 to 1 110	w, a	yes	A
X2CrNiMo17-12-2	1.4404	190	225	490 to 690	40	30	100	60	60	1 020 to 1 120	w, a	yes	A
X5CrNiMo17-12-2	1.4401	205	240	510 to 710	40	30	100	60	60	1 020 to 1 120	w, a	yes ^g	A
X1CrNiMoN25-22-2	1.4466	260	295	540 to 740	40	30	100	60	60	1 070 to 1 150	w, a	yes	A or B
X6CrNiMoTi17-12-2 (cold finish)	1.4571	210	245	500 to 730	35	30	100	60	-	1 020 to 1 120	w, a	yes	A
X6CrNiMoTi17-12-2 (hot finish)	1.4571	190	225	490 to 690	35	30	100	60	60	1 020 to 1 120	w, a	yes	A
X6CrNiMoNb17-12-2	1.4580	215	250	510 to 740	35	30	100	60	-	1 020 to 1 120	w, a	yes	A
X2CrNiMoN17-13-3	1.4429	295	330	580 to 800	35	30	100	60	60	1 020 to 1 120	w, a	yes	A
X3CrNiMo17-13-3	1.4436	205	240	510 to 710	40	30	100	60	60	1 020 to 1 120	w, a	yes ^g	A
X2CrNiMo18-14-3	1.4435	190	225	490 to 690	40	30	100	60	60	1 020 to 1 120	w, a	yes	A

Steel grade		Tensile properties at room temperature ^c					Impact properties ^c			Reference heat treatment conditions		Resistance to intergranular corrosion	
		Proof strength		Tensile strength	Elongation		Minimum average absorbed energy KV ^J						
		$R_{p0,2}$ min	$R_{p1,0}$ min	R_m	A min (%)		at RT	at -196°C		Solution temperature ^d °C	Cooling in ^e	f	Method in EN ISO 3651-2
Steel name	Steel number	MPa	MPa	MPa	l	t	l	t	t				
X2CrNiMoN17-13-5	1.4439	285	315	580 to 800	35	30	100	60	60	1 060 to 1 140	w, a	yes	A
X1NiCrMoCu31-27-4	1.4563	215	245	500 to 750	40	35	120	90	60	1 070 to 1 150	w, a	yes	B or C
X1NiCrMoCu25-20-5	1.4539	230	250	520 to 720	35	30	120	90	60	1 060 to 1 140	w, a	yes	C
X1CrNiMoCuN20-18-7	1.4547	300	340	650 to 850	35	30	100	60	60	1 140 to 1 200	w, a	yes	C
X1NiCrMoCuN25-20-7	1.4529	270	310	600 to 800	35	30	100	60	60	1 120 to 1 180	w, a	yes	C
X2NiCrAlTi32-20	1.4558	180	210	450 to 700	35	30	120	90	60	950 to 1 050	w, a	yes	A

- ^a For wall thicknesses greater than 60 mm the mechanical properties are subject to agreement at the time of enquiry and order. **Option 7: Agreed mechanical properties for wall thicknesses greater than 60 mm apply.**
- ^b Inspection and testing to be carried out are summarised in Table 15.
- ^c l = longitudinal; t = transverse.
- ^d The maximum temperatures are for guidance only.
- ^e w = water; a = air; cooling sufficiently rapid.
- ^f When tested according to EN ISO 3651-2 (Appropriate method, A or B or C, as indicated) up to the limit temperatures indicated in the last column of Table 9.
- ^g In delivery condition. (Normally not fulfilled in the sensitized condition).

Table 7 - Mechanical properties for wall thicknesses up to 50 mm ^a of austenitic creep resisting steels in the solution annealed condition (+AT) and information about intergranular corrosion ^b

Steel grade		Tensile properties at room temperature ^c					Impact properties at room temperature ^c		Reference heat treatment conditions		Resistance to intergranular corrosion	
		Proof strength		Tensile strength	Elongation		Minimum average absorbed energy KV J		Solution temperature ^d °C	Cooling in ^e	f	Method in EN ISO 3651-2
		$R_{p0,2}$ min	$R_{p1,0}$ min	R_m	A min (%)							
Steel name	Steel number	MPa	MPa	MPa	l	t	l	t				
X6CrNi18-10	1.4948	185	225	500 to 700	40	30	100	60	1 000 to 1 080	w, a	no	A
X7CrNiTi18-10	1.4940	190	220	510 to 710	35	30	100	60	1 100 to 1 150	w, a	no	A
X7CrNiNb18-10	1.4912	205	240	510 to 710	40	30	100	60	1 070 to 1 125	w, a	no	A
X6CrNiTiB18-10	1.4941	195	235	490 to 680	35	30	100	60	1 070 to 1 150	w, a	no	A
X6CrNiMo17-13-2	1.4918	205	245	490 to 690	35	30	100	60	1 020 to 1 100	w, a	no	A
X5NiCrAlTi31-20	1.4958	170	200	500 to 750	35	30	120	80	1 150 to 1 200	w, a	no	A
X5NiCrAlTi31-20 + RA	1.4958+RA	210	240	500 to 750	35	30	120	80	920 to 1 000 ^g	w,a	no	A
X8NiCrAlTi32-21	1.4959	170	200	500 to 750	35	30	120	80	1 150 to 1 200 ^h	w, a	no	A
X3CrNiMoBN17-13-3	1.4910	260	300	550 to 750	35	30	120	80	1 020 to 1 100	w, a	no	A
X8CrNiNb16-13	1.4961	205	245	510 to 690	35	22	100	60	1 050 to 1 100	w, a	no	A
X8CrNiMoVNb16-13	1.4988	255	295	540 to 740	30	20	60	40	1 100 to 1 150 ⁱ	w, a	no	A
X8CrNiMoNb16-16	1.4981	215	255	530 to 690	35	22	100	60	1 050 to 1 100	w,a	no	A
X10CrNiMoMnNbVB15-10-1	1.4982	220	270	540 to 740	35	30	100	60	1 050 to 1 150	w, a	no	A

^a For wall thicknesses greater than 50 mm the mechanical properties are subject to agreement at the time of enquiry and order. **Option 8: Agreed mechanical properties for wall thicknesses greater than 50 mm apply.**

^b Inspection and testing to be carried out are summarised in Table 15.

^c l = longitudinal; t = transverse.

^d The maximum temperatures are for guidance only.

^e w = water; a = air; cooling sufficiently rapid.

^f When tested according to EN ISO 3651-2 (Appropriate method, A or B or C, as indicated) up to the limit temperatures indicated in the last column of Table 10.

^g After solution annealing the grain size shall be 1 to 5 according to EN ISO 643.

^h After solution annealing the grain size according to EN ISO 643 shall be 1 to 5 for cold worked tube and 5 or coarser for hot extruded tube.

ⁱ Additionally to be tempered at 750 °C to 800 °C, 1 to 5 h and air cooling.

Table 8 - Mechanical properties for wall thicknesses up to 30 mm of austenitic-ferritic steels in the solution annealed condition (+AT) and information about intergranular corrosion ^a

Steel grade		Tensile properties at room temperature ^b				Impact properties ^b			Reference heat treatment conditions		Resistance to intergranular corrosion	
		Proof strength $R_{p0,2}$ min.	Tensile strength R_m	Elongation		Minimum average absorbed energy KV J						
Steel name	Steel number			MPa	MPa	l	t	l	t	t	Solution temperature ^c	Cooling in ^d
		X2CrNiMoN22-5-3	1.4462			450	640 to 880 ^f	22	22	120		
X2CrNiMoSi18-5-3	1.4424	480	700 to 900	30	30	120	80	-	975 to 1 050	w, a	yes	A
X2CrNiN23-4	1.4362	400	600 to 820	25	25	120	90	40	950 to 1 050	w, a	yes	A
X2CrNiMoN25-7-4	1.4410	550	800 to 1000	20	20	100	100	40	1 040 to 1 120	w, a	yes	B or C
X2CrNiMoCuN25-6-3	1.4507	500	700 to 900	20	20	100	100	40	1 040 to 1 120	w	yes	B
X2CrNiMoCuWN 25-7-4	1.4501	550	800 to 1 000	20	20	100	100	40	1 040 to 1 120	w	yes	B or C

^a Inspection and testing to be carried out are summarised in Table 15.

^b l = longitudinal; t = transverse.

^c The maximum temperatures are for guidance only.

^d w = water; a = air; cooling sufficiently rapid.

^e When tested according to EN ISO 3651-2 (Appropriate method, A or B or C, as indicated) up to the limit temperatures indicated in the last column of Table 11.

^f For cold finished and solution annealed tubes the maximum tensile strength is 920 MPa.

Table 9 - Minimum proof strength $R_{p0,2}$ and $R_{p1,0}$ at elevated temperatures for wall thicknesses up to 60 mm^a of austenitic corrosion resisting steels in the solution annealed condition (+AT) and guideline for the limit temperature for intergranular corrosion (continued)

Steel grade		$R_{p0,2}$, min MPa at a temperature (°C) of											$R_{p1,0}$, min MPa at a temperature (°C) of											Limit temp. ^b °C
Steel name	Steel number	50	100	150	200	250	300	350	400	450	500	550	50	100	150	200	250	300	350	400	450	500	550	
X2CrNi18-9	1.4307	165	145	130	118	108	100	94	89	85	81	80	200	180	160	145	135	127	121	116	112	109	108	350
X2CrNi19-11	1.4306	165	145	130	118	108	100	94	89	85	81	80	200	180	160	145	135	127	121	116	112	109	108	350
X2CrNiN18-10	1.4311	255	205	175	157	145	136	130	125	121	119	118	282	240	210	187	175	167	160	156	152	149	147	400
X5CrNi18-10	1.4301	180	155	140	127	118	110	104	98	95	92	90	218	190	170	155	145	135	129	125	122	120	120	300
X6CrNiTi18-10 (cold finish.) (hot finish.)	1.4541	190	176	167	157	147	136	130	125	121	119	118	222	208	195	185	175	167	161	156	152	149	147	400
	1.4541	162	147	132	118	108	100	94	89	85	81	80	201	181	162	147	137	127	121	116	112	109	108	400
X6CrNiNb18-10	1.4550	195	175	165	155	145	136	130	125	121	119	118	232	210	195	185	175	167	161	156	152	149	147	400
X1CrNi25-21	1.4335	170	150	140	130	120	115	110	105	-	-	-	200	180	170	160	150	140	135	130	-	-	-	400
X2CrNiMo17-12-2	1.4404	182	165	150	137	127	119	113	108	103	100	98	217	200	180	165	153	145	139	135	130	128	127	400
X5CrNiMo17-12-2	1.4401	196	175	158	145	135	127	120	115	112	110	108	230	210	190	175	165	155	150	145	141	139	137	300
X1CrNiMoN25-22-2	1.4466	230	195	170	160	150	140	135	-	-	-	-	262	225	205	190	180	170	165	-	-	-	-	400
X6CrNiMoTi17-12-2 (cold fin.) (hot fin.)	1.4571	202	185	177	167	157	145	140	135	131	129	127	234	208	195	185	175	167	161	156	152	149	147	400
	1.4571	182	166	152	137	127	118	113	108	103	100	98	201	181	162	147	137	127	121	116	112	109	108	400
X6CrNiMoNb17-12-2	1.4580	202	186	177	167	157	145	140	135	131	129	127	240	221	206	196	186	175	169	164	160	158	157	400
X2CrNiMoN17-13-3	1.4429	255	215	195	175	165	155	150	145	140	138	136	290	245	225	205	195	185	180	175	170	168	166	400
X3CrNiMo17-13-3	1.4436	195	175	158	145	135	127	120	115	112	110	108	228	210	190	175	165	155	150	145	141	139	137	300
X2CrNiMo18-14-3	1.4435	180	165	150	137	127	119	113	108	103	100	98	217	200	180	165	153	145	139	135	130	128	127	400
X2CrNiMoN17-13-5	1.4439	260	225	200	185	175	165	155	150	-	-	-	290	255	230	210	200	190	180	175	-	-	-	400
X1NiCrMoCu31-27-4	1.4563	210	190	175	160	155	150	145	135	125	120	115	240	220	205	190	185	180	175	165	155	150	146	550
X1NiCrMoCu25-20-5	1.4539	221	205	190	175	160	145	135	125	115	110	105	244	235	220	205	190	175	165	155	145	140	135	400
X1CrNiMoCuN20-18-7	1.4547	267	230	205	190	180	170	165	160	153	148	-	306	270	245	225	212	200	195	190	184	180	-	400

Steel grade		$R_{p0,2}$, min MPa at a temperature (°C) of											$R_{p1,0}$, min MPa at a temperature (°C) of											Limit temp. ^b °C
Steel name	Steel number	50	100	150	200	250	300	350	400	450	500	550	50	100	150	200	250	300	350	400	450	500	550	
X1NiCrMoCuN25-20-7	1.4529	254	230	210	190	180	170	165	160	-	-	-	296	270	245	225	215	205	195	190	-	-	-	400
X2NiCrAlTi32-20	1.4558	168	155	145	140	135	130	125	120	110	100	90	198	185	175	170	165	160	155	150	140	130	120	400

^a For wall thicknesses greater than 60 mm the proof strength values are subject to agreement at the time of enquiry and order. **Option 10:** Agreed proof strength values for wall thicknesses greater than 6 mm apply.

^b Up to these temperatures, the material should, within 100 000 h, not have changed so as to show susceptibility to intergranular corrosion, when tested in conformity with EN ISO 3651-2. See also Table 6.

Table 10 - Minimum proof strength $R_{p0,2}$ and $R_{p1,0}$ at elevated temperatures for wall thicknesses up to 50 mm of austenitic creep resisting steels in the solution annealed condition (+AT) and guideline for the limit temperature for intergranular corrosion

Steel grade		$R_{p0,2}$, min MPa											$R_{p1,0}$, min MPa											Limit temp. ^a °C
		Temperature (°C)											Temperature (°C)											
Steel name	Steel number	50	100	150	200	250	300	350	400	450	500	550	50	100	150	200	250	300	350	400	450	500	550	
X6CrNi18-10	1.4948	174	157	142	127	117	108	103	98	93	88	83	201	191	172	157	147	137	132	127	122	118	113	400
X7CrNiTi18-10	1.4940	172	156	145	135	128	124	120	116	113	111	109	207	191	179	170	163	159	155	151	148	146	144	400
X7CrNiNb18-10	1.4912	190	171	162	153	147	139	133	129	-	124	-	225	204	192	182	172	166	162	159	-	155	-	
X6CrNiTiB18-10	1.4941	180	162	152	142	137	132	127	123	118	113	108	219	201	191	181	176	172	167	162	157	152	147	400
X6CrNiMo17-13-2	1.4918	184	177	162	147	137	127	122	118	113	108	103	228	211	194	177	167	157	152	147	142	137	132	400
X5NiCrAlTi31-20	1.4958	157	140	127	115	105	95	90	85	82	80	75	180	160	147	135	125	115	110	105	102	100	95	400
X5NiCrAlTi31-20 +RA	1.4958+RA	195	180	170	160	152	145	137	130	125	120	115	225	205	193	180	172	165	160	155	150	145	140	400
X8NiCrAlTi32-21	1.4959	157	140	127	115	105	95	90	85	82	80	75	180	160	147	135	125	115	110	105	102	100	95	400
X3CrNiMoBN17-13-3	1.4910	234	205	187	170	159	148	141	134	130	127	124	273	240	220	200	189	178	171	164	160	157	154	400
X8CrNiNb16-13	1.4961	197	175	166	157	147	137	132	128	123	118	118	231	205	195	186	176	167	162	157	152	147	147	400
X8CrNiMoVNb16-13	1.4988	239	215		196		177		167		157	152	273	245		226		206		196		186	181	400
X8CrNiMoNb16-16	1.4981	202	195		177		157		147		137	137	242	225		206		186		177		167	167	400
X10CrNiMoMnNbVB15-10-1	1.4982	213	188	171	161	153	148	145	144	141	139	136	254	232	210	195	190	187	184	182	179	178	175	400

^a Up to these temperatures, the material should, within 100 000 h, not have changed so as to show susceptibility to intergranular corrosion, when tested in conformity with EN ISO 3651-2. See also Table 7.

Table 11 - Minimum proof strength $R_{p0,2}$ at elevated temperatures for wall thicknesses up to 30 mm of austenitic-ferritic steels in the solution annealed (+AT) condition and guideline for the limit temperature for intergranular corrosion

Steel grade		$R_{p0,2}$ min MPa Temperature °C				
Steel name	Steel number	50	100	150	200	250 ^a
X2CrNiMoN22-5-3	1.4462	415	360	335	310	295
X2CrNiMoSi18-5-3	1.4424	430	370	350	330	325
X2CrNiN23-4	1.4362	370	330	310	290	280
X2CrNiMoN25-7-4	1.4410	530	480	445	420	405
X2CrNiMoCuN25-6-3	1.4507	485	450	420	400	380
X2CrNiMoCuWN25-7-4	1.4501	502	450	420	400	380

^a Up to this temperature, the material should, within 100 000 h, not have changed so as to show susceptibility to intergranular corrosion, when tested in conformity with EN ISO 3651-2. See also Table 8.

8.4 Corrosion resistance

The information given in Tables 6, 7 and 8 refer to the resistance of the steels to intergranular corrosion when tested in accordance with EN ISO 3651-2 to the indicated method A or B or C.

Guideline values for the limit temperature for susceptibility to intergranular corrosion are indicated in Tables 9, 10 and 11.

Option 12: A test for the resistance to intergranular corrosion shall be carried out.

If other specific corrosion tests are required, they shall be agreed at the time of enquiry and order.

8.5 Appearance and soundness

8.5.1 Appearance

8.5.1.1 The tubes shall be free from external and internal surface defects that can be detected by visual examination.

8.5.1.2 The internal and external surface finish of the tubes shall be typical of the manufacturing process and, where applicable, the heat treatment employed. Normally the finish and surface condition shall be such that any surface imperfections requiring dressing can be identified.

8.5.1.3 It shall be permissible to dress, only by grinding or machining, surface imperfections provided that, after doing so, the wall thickness in the dressed area is not less than the specified minimum wall thickness. All dressed areas shall blend smoothly into the contour of the tube.

8.5.1.4 Surface imperfections which encroach on the specified minimum wall thickness shall be considered defects and tubes containing these shall be deemed not to conform to this part of EN 10216.

8.5.2 Soundness

8.5.2.1 Leak-tightness

The tubes shall pass a hydrostatic test (see 11.6.1) or an eddy current test (see 11.6.2) for leak-tightness.

Unless option 13 is specified, the choice of the test method is at the discretion of the manufacturer.

EN 10216-5:2004 (E)

Option 13: The test method for verification of leak-tightness according to 11.6.1 or 11.6.2 is specified by the purchaser.

8.5.2.2 Non-destructive testing

The tubes of test category 2 with outside diameter greater than 101,6 mm or wall thickness greater than 5,6 mm shall be submitted to a non-destructive testing for the detection of longitudinal imperfections, according to 11.9.1.

Option 14: The tubes of test category 2 with specified outside diameter less than or equal to 101,6 mm and specified wall thickness less than or equal to 5,6 mm shall be submitted to a non-destructive testing for the detection of longitudinal imperfections according to 11.9.1.

Option 15: The tubes of test category 2 shall be submitted to a non-destructive testing for the detection of transverse imperfections according to 11.9.2.

Option 16: The tubes of test category 2 with specified wall thickness greater than 40 mm shall be submitted to a non-destructive testing for the detection of the laminar imperfections at the tube ends according to 11.9.3.

8.6 Straightness

The deviation from straightness of any tube length L shall not exceed $0,0015 L$. Deviations from straightness over any one meter length shall not exceed 3 mm.

8.7 Preparation of ends

Tubes shall be delivered with square cut ends. The ends shall be free from excessive burrs.

Option 17: Tubes with wall thickness $T \geq 3,2$ mm shall be delivered with bevelled ends (see Figure 1). The bevel shall have an angle α of $30^\circ +5^\circ_0$ with a root face C of $1,6 \text{ mm} \pm 0,8 \text{ mm}$, except that for wall thickness T greater than 20 mm, an agreed alternative bevel may be specified.

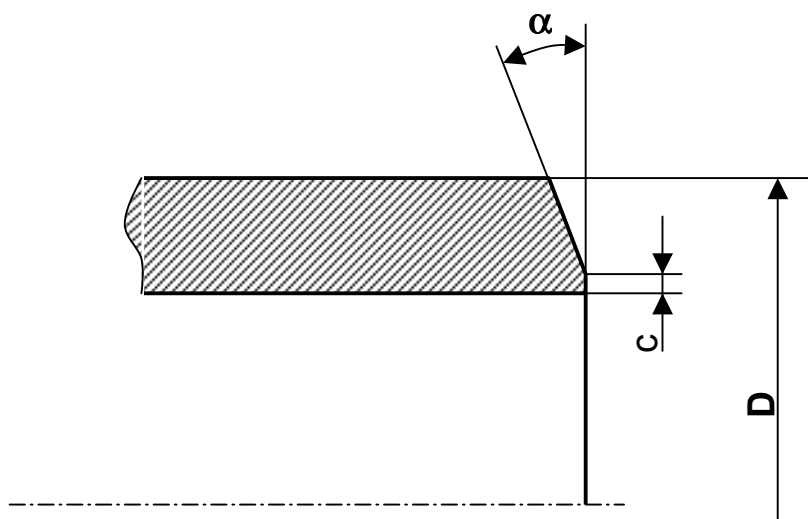

Figure 1 — Tube end bevel

8.8 Dimensions, masses and tolerances

8.8.1 Outside diameter and wall thickness

Tubes shall be ordered by outside diameter D and wall thickness T . Preferred outside diameters D and wall thicknesses T are given in EN ISO 1127.

8.8.2 Mass

For the calculation of mass per unit length the density values given in EN 10088-1, Table A.1 to Table A.4 and EN 10028-7, Table A.1 shall be used.

8.8.3 Lengths

Unless option 18 is specified, the tubes shall be delivered in random lengths. The delivery range shall be agreed at the time of enquiry and order.

Option 18: The tubes shall be delivered in exact lengths and the length shall be specified at the time of enquiry and order. The tolerances on these lengths shall conform to 8.8.4.2.

8.8.4 Tolerances

8.8.4.1 Tolerances on outside diameter and wall thickness

The diameter and the wall thickness of the tubes shall be within the relevant tolerance limits given in Table 12 for hot finished tubes and in Table 13 for cold finished tubes. Tolerance classes T1 to T4 and D1 to D4 were taken from EN ISO 1127.

Out of roundness is included in the tolerances on diameter and eccentricity is included in the tolerances on wall thickness.

Table 12 - Tolerances on outside diameter D and wall thickness T for tubes ordered hot finished

Outside diameter D mm	Tolerances on D		Tolerances on T	
	Tolerance class	Permissible deviation	Tolerance class	Permissible deviation
$30 \leq D \leq 219,1$	D 2	$\pm 1,0 \%$ or $\pm 0,5$ mm whichever is the greater	T 1	$\pm 15 \%$ or $\pm 0,6$ mm whichever is the greater ^b
			T 2	$\pm 12,5 \%$ or $\pm 0,4$ mm whichever is the greater
$219,1 < D \leq 610$	D 1	$\pm 1,5 \%$ or $\pm 0,75$ mm whichever is the greater ^a		+ 22,5 % - 15 % ^c
			T 1	$\pm 15 \%$ or $\pm 0,6$ mm whichever is the greater ^d
			T 2	$\pm 12,5 \%$ or $\pm 0,4$ mm whichever is the greater ^e

^a **Option 19:** The tubes shall be ordered with sized ends. In this case a permissible deviation of the outside diameter of $\pm 0,6 \%$ applied to the tube ends over a length of approx. 100 mm.

^b Applies to tubes with wall thickness $T \leq 0,01 D$ and $T \leq 4$ mm.

^c Applies to tubes with wall thickness $T \leq 0,05 D$.

^d Applies to tubes with wall thickness $T: 0,05 D < T \leq 0,09 D$.

^e Applies to tubes with wall thickness $T > 0,09 D$.

EN 10216-5:2004 (E)

Table 13 - Tolerances on outside diameter D and wall thickness T for tubes ordered cold finished

Tolerances on $D \leq 219,1$ mm		Tolerances on T	
Tolerance class	Permissible deviation	Tolerance class	Permissible deviation
D 3	$\pm 0,75$ % or $\pm 0,3$ mm whichever is the greater	T 3	± 10 % or $\pm 0,2$ mm whichever is the greater
D 4 ^a	$\pm 0,5$ % or $\pm 0,1$ mm whichever is the greater	T 4 ^a	$\pm 7,5$ % or $\pm 0,15$ mm whichever is the greater
^a Option 20: Tolerance classes D 4 and T 4 is specified for tubes ordered cold finished			

8.8.4.2 Tolerance on exact lengths

The tolerances for exact lengths shall be as given in Table 14.

Table 14 - Tolerances on exact lengths

Dimensions in mm

Length L	Tolerance on exact length
$L \leq 6\ 000$	+ 5 0
$6\ 000 < L \leq 12\ 000$	+ 10 0
$L > 12\ 000$	+ by agreement 0

9 Inspection

9.1 Type of inspection

Conformity to the requirements of the order, for tubes according to this part of EN 10216, shall be verified by specific inspection.

When an inspection document 3.1.B is specified the material manufacturer shall state in the confirmation of the order whether he is operating according to a "quality-assurance system", certified by a competent Body established within the Community, and whether he has undergone a specific assessment for materials.

NOTE See the EU Directive 97/23/EC Annex I section 4.3 third paragraph.

9.2 Inspection documents

9.2.1 Types of inspection documents

Unless option 21 is specified, an inspection certificate 3.1.B, according to EN 10204, shall be issued.

Option 21: One of the inspection documents 3.1.C or 3.2 according to EN 10204 shall be issued.

If an inspection document 3.1.C or 3.2 is specified, the purchaser shall notify the manufacturer of the name and address of the organisation or person who is to carry out the inspection and produce the inspection document. In the case of the inspection report 3.2 it shall be agreed which party shall issue the certificate.

NOTE Document 3.1.A is not acceptable for compliance with the EU Directive 97/23/EC.

9.2.2 Content of inspection documents

The content of the inspection document shall be according to EN 10168.

In all types of inspection documents a statement on the conformity of the products delivered with the requirements of this specification and the order shall be included.

The inspection certificate or inspection report shall contain the following codes and information:

- A commercial transactions and parties involved;
- B description of products to which the inspection document applies;
- C02-C03 direction of the test pieces and testing temperature;
- C10-C13 tensile test;
- C40-C43 impact test, if applicable;
- C60-C69 other tests (e.g. flattening);
- C71-C92 chemical composition on cast analysis (product analysis if applicable);
- D01 marking and identification, surface appearance, shape and dimensional properties;
- D02-D99 leak-tightness test, NDT, material identification;
- Z validation.

In addition for inspection document 3.1.B the manufacturer shall state the references to the certificate (see 9.1) of the appropriate "quality-assurance system", if applicable.

9.3 Summary of inspection and testing

The tubes shall be inspected and tested in accordance with test category 1 or test category 2 as specified at the time of enquiry and order (see 6.1).

Inspection and testing to be carried out are summarised in Table 15.

10 Sampling

10.1 Test unit

For heat treated tubes, a test unit shall comprise tubes of the same specified diameter and wall thickness, the same steel grade, the same cast, the same manufacturing process, subjected to the same finishing treatment in a continuous furnace or heat treated in the same furnace charge in a batch-type furnace.

For extruded tubes, a test unit shall comprise tubes of the same specified diameter and wall thickness, the same steel grade, the same cast, the same manufacturing process.

The number of tubes, in random manufacturing lengths¹⁾ per test unit shall be max 100.

¹⁾ The random manufacturing lengths may differ from the delivery length (see 8.8.3).

EN 10216-5:2004 (E)

Table 15 - Summary of inspection and testing

Type of inspection and test		Frequency of testing		Refer to	Testing standard
		Test category 1	Test category 2		
Mandatory tests	Cast analysis	one per cast	one per cast	11.1	
	Tensile test at room temperature	one per test unit	two per test unit	11.2.1	EN 10002-1
	Flattening test ^a or	one per test unit	10 % per test unit (at least one per test unit)	11.3.1	EN 10233
	Ring tensile test ^a or			11.3.2	EN 10237
	Drift expanding test ^a or			11.3.3	EN 10234
	Ring expanding test ^a			11.3.4	EN 10236
	Leak tightness test	each tube	each tube	11.6	EN 10246-2
	Dimensional inspection			11.7	
	Visual examination			11.8	
	NDT for the detection of longitudinal imperfections for D > 101,6 mm or T > 5,6 mm	-		11.9	EN 10246-7
Material identification	each tube		11.10		
Optional tests	Product analysis (option 4)	one per cast	one per cast	11.1	
	Tensile test at elevated temperature (option 9)	as agreed upon or one per cast and same heat treatment condition	as agreed upon or one per cast and same heat treatment condition	11.2.2	EN 10002-5
	Impact test at room temperature (option 6)			11.4	EN 10045-1
	Impact test at low temperature (option 11)			11.4	EN 10045-1
	Intergranular corrosion test (option 12)			11.5	EN ISO 3651-2
	Wall thickness measurement away from tube ends (option 23)	each tube	each tube	11.7	
	NDT for the detection of longitudinal imperfections for D ≤ 101,6 mm and T ≤ 5,6 mm (option 14)	-		11.9	EN 10246-7
	NDT for the detection of transverse imperfections (option 15)	-		11.9	EN 10246-6
	NDT for the detection of laminar imperfections at tubes ends for T > 40 mm. (option 16)	-		11.9	EN 10246-17

^a Testing method is at the manufacturer's discretion in accordance with Table 16.

10.2 Preparation of samples and test pieces

10.2.1 Selection and preparation of samples for product analysis

Samples for product analysis shall be taken from the test pieces or samples for mechanical testing or from the whole thickness of the tube at the same location as for the mechanical test samples, according to EN ISO 14284.

10.2.2 Location, orientation and preparation of samples and test pieces for mechanical tests

10.2.2.1 General

Samples and test pieces shall be taken at the tube ends and according to the requirements of EN ISO 377.

10.2.2.2 Test pieces for tensile test

The test pieces for tensile tests at room temperature shall be prepared according to EN 10002-1.

The test pieces for tensile tests at elevated temperature shall be prepared according to EN 10002-5.

At the manufacturer's discretion:

- for tubes with an outside diameter $D \leq 219,1$ mm the test piece shall be either a full tube section or a strip section or a machined circular cross section ($T > 10$ mm) and shall be taken in a direction either transverse, where possible, or longitudinal to the axis of the tube;
- for tubes with an outside diameter $D > 219,1$ mm, the test piece shall either be a machined circular cross section ($T > 10$ mm) from an unflattened sample or a strip section and be taken in a direction either transverse, where possible, or longitudinal to the axis of the tube.

10.2.2.3 Test pieces for flattening, ring tensile, drift expanding and ring expanding tests

The test pieces for the flattening, ring tensile, drift expanding and ring expanding tests shall consist of a full tube section according to EN 10233, EN 10237, EN 10234 or EN 10236 respectively.

10.2.2.4 Test pieces for impact test

Three standard Charpy V-notch test pieces shall be prepared according to EN 10045-1. If the nominal product thickness is such that standard test pieces cannot be produced without flattening of the section, then the test pieces of width less than 10 mm, but not less than 5 mm shall be prepared; the largest obtainable width shall be used.

Where test pieces of at least 5 mm width cannot be obtained, the tubes shall not be subjected to impact testing.

The test pieces shall be taken transverse to the tube axis unless D_{\min} , as calculated by the following equation, is greater than the specified outside diameter, in which case longitudinal test pieces shall be used:

$$D_{\min} = (T-5) + [756,25 / (T-5)] \quad (1)$$

The test pieces shall be prepared such that the axis of the notch is perpendicular to the surface of the tube, see Figure 2.

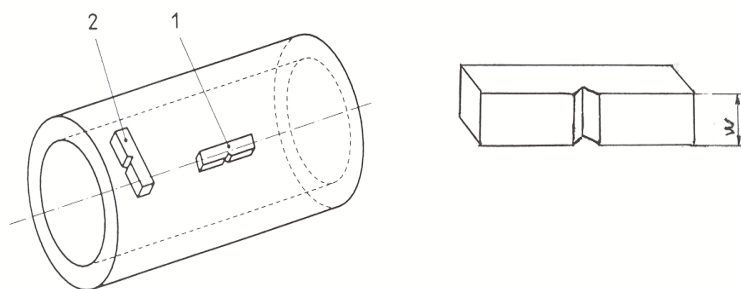
EN 10216-5:2004 (E)**Key**

1 Longitudinal test piece

2 Transverse test piece

Notch oriented perpendicular to tube axis

Figure 2 — Impact test piece orientation

10.2.2.5 Test pieces for intergranular corrosion test

The test pieces for the intergranular corrosion test shall be prepared according to EN ISO 3651-2.

11 Test methods**11.1 Chemical analysis**

The elements to be determined and reported shall be those specified in Tables 2, 3 and 4. The choice of a suitable physical or chemical analytical method for the analysis shall be at the discretion of the manufacturer. In case of dispute the method used shall be agreed between manufacturer and purchaser taking into account CR 10261.

11.2 Tensile test**11.2.1 At room temperature**

The test shall be carried out at room temperature according to EN 10002-1, and the following determined:

- tensile strength (R_m);
- 0,2 % proof strength ($R_{p0,2}$) and, where applicable, the 1,0 % proof strength ($R_{p1,0}$);
- percentage elongation after fracture with reference to a gauge length (L_0) of $5,65 \sqrt{S_0}$; if a non proportional test piece is used, the percentage elongation value shall be converted to the value for a gauge length $L_0 = 5,65 \sqrt{S_0}$ using the conversion tables in EN ISO 2566-2.

11.2.2 At elevated temperature

The test shall be carried out according to EN 10002-5 at the temperature agreed at the time of enquiry and order (see 6.2) and the 0,2 % proof strength ($R_{p0,2}$) and, where applicable, the 1,0 % proof strength ($R_{p1,0}$) shall be determined.

11.3 Technological tests

Depending on the tube dimensions one of the tests given in Table 16 shall be carried out.

Table 16 – Technological tests

Outside diameter D mm	Wall thickness T mm		
	< 2	2 ≤ T ≤ 16	16 < T ≤ 40
≤ 18	Flattening test ^a	Flattening test ^a	-
> 18 ≤ 150	Flattening test ^a	Ring expanding test ^a	Flattening test ^b
> 150	-	Ring tensile test	Ring tensile test ^{c, d}

^a The test may, at the discretion of the manufacturer, be replaced by drift expanding test for wall thicknesses ≤ 10 mm.
^b For T/D ≤ 0,15.
^c The test may, at the discretion of the manufacturer, be replaced by flattening test for T/D ≤ 0,15.
^d Inside diameter ≥ 100 mm.

11.3.1 Flattening test

The test shall be carried out according to EN 10233.

The tube section shall be flattened in a press until the distance H between the platens reaches the value given by the following equation:

$$H = \frac{1+C}{C+T/D} \times T \quad (2)$$

where

H is the distance between platens, in mm, to be measured under load;

D is the specified outside diameter, in mm;

T is the specified wall thickness, in mm;

C is the constant factor of deformation, which is:

- 0,09 for austenitic steels and
- 0,07 for austenitic-ferritic steels.

After testing, the test piece shall be free from cracks or breaks. However, slight incipient cracks at its edges shall not be regarded as justification for rejection.

11.3.2 Ring tensile test

The test shall be carried out according to EN 10237.

The tube section shall be subjected to strain in the circumferential direction until fracture occurs.

After fracture the test pieces shall not show any visible cracks without the use of magnifying aids (excluding the fracture point).

EN 10216-5:2004 (E)**11.3.3 Drift expanding test**

The test shall be carried out according to EN 10234.

The tube section shall be expanded with a 60° conical tool until the % increase in outside diameter shown in Table 17 is reached.

Table 17 - Drift expanding test requirements

% increase in outside diameter for d/D ^a		
$\leq 0,6$	$0,6 < d/D \leq 0,8$	$> 0,8$
9	15	17
^a $d = D - 2T$.		

After testing, the test piece shall (excluding the fracture point) be free from cracks or breaks. However, slight incipient cracks at its edges shall not be regarded as justification for rejection.

11.3.4 Ring expanding test

The test shall be carried out according to EN 10236.

The tube section shall be expanded with a conical tool until it breaks. If an expansion of 40 % of the inside diameter for austenitic steels and of 30 % for austenitic-ferritic steels is reached the test may be considered as finished.

The surface outside the fracture zone shall excluding the fracture point be free from cracks or breaks. However, slight incipient cracks at its edges shall not be regarded as justification for rejection.

11.4 Impact test

11.4.1 The test shall be carried out according to EN 10045-1 at the temperature specified by the applicable option (see 6.2).

11.4.2 The mean value of the three test pieces shall meet the requirements given in Tables 6, 7 or 8. One individual value may be below the specified value, provided that it is not less than 70 % of that value.

11.4.3 If the width (W) of the test piece is less than 10 mm, the measured impact energy (KV_p) shall be converted to impact energy (KV_c) using the following equation:

$$KV_c = \frac{10 \times KV_p}{W} \quad (3)$$

where

- KV_c is the calculated impact energy, in J;
- KV_p is the measured impact energy, in J;
- W is the width of the test piece, in mm.

The calculated impact energy KV_c shall comply with the requirements given in 11.4.2.

11.4.4 If the requirements of 11.4.2 are not met, then an additional set of three test pieces may be taken at the discretion of the manufacturer from the same sample and tested. To consider the test unit as conforming, after testing the second set, the following conditions shall be satisfied simultaneously:

- the average value of six tests shall be equal to or greater than the specified minimum average value;

- not more than two of six individual values may be lower than the specified minimum average value;
- not more than one of the six individual values may be lower than 70 % of the specified minimum average value.

11.4.5 The dimensions in millimetres of the test pieces, the measured impact energy values and the resulting average value shall be reported.

11.5 Intergranular corrosion test

The intergranular corrosion test shall be carried out according to EN ISO 3651-2 to the specified method (A or B or C).

11.6 Leak tightness test

11.6.1 Hydrostatic test

The hydrostatic test shall be carried out at a test pressure P of 70 bar²⁾ or at a test pressure calculated using the following equation, whichever is lower:

$$P = 20 \frac{S \times T}{D} \quad (4)$$

where

P is the test pressure, in bar;

D is the specified outside diameter, in mm;

T is the specified wall thickness, in mm;

S is the stress, in MPa, corresponding to 70 % of the specified minimum proof strength ($R_{p0,2}$) (see Tables 6, 7 and 8) for the steel grade concerned.

The test pressure shall be held for not less than 5s for tubes with an outside diameter D less than or equal to 457 mm and for not less 10 s for tubes with an outside diameter greater than 457 mm.

The tube shall withstand the test without showing leakage or visible deformation.

NOTE This hydrostatic leak-tightness test is not a strength test.

Option 22: A test pressure different from that specified in 11.6.1 and corresponding to a stress below 90 % of the specified minimum proof strength ($R_{p0,2}$) (see Tables 6, 7 and 8) for the steel grade concerned is specified.

11.6.2 Eddy current test

The test shall be carried out according to EN 10246-2.

11.7 Dimensional inspection

Specified dimensions, including straightness, shall be verified.

The outside diameter shall be measured at the tube ends. For tubes with outside diameter $D \geq 406,4$ mm, the diameter may be measured using a circumference tape.

Unless option 23 is specified the wall thickness shall be measured at both tube ends.

²⁾ 1 bar = 100 kPa.

EN 10216-5:2004 (E)

Option 23: *The wall thickness shall be measured away from the tube ends according to an agreed procedure.*

11.8 Visual examination

Tubes shall be visually examined to ensure conformity to the requirements of 8.5.1.

11.9 Non-destructive testing

11.9.1 Tubes of test category 2 with outside diameter $D > 101,6$ mm or wall thickness $T > 5,6$ mm shall be subjected to ultrasonic testing for the detection of longitudinal imperfections, according to EN 10246-7, to acceptance level U2, sub-category C.

Regions at the tube ends not automatically tested shall either be subjected to manual/semi-automatic ultrasonic testing according to EN 10246-7 to acceptance level U2, sub-category C or be cropped off.

If option 14 (see 8.5.2.2) is specified, the tubes with outside diameter $D \leq 101,6$ mm and wall thickness $T \leq 5,6$ mm shall be subjected to ultrasonic testing for the detection of longitudinal imperfections according to EN 10246-7 to acceptance level U2, sub-category C.

11.9.2 If option 15 (see 8.5.2.2) is specified, the tubes shall be subjected to ultrasonic testing for the detection of transverse imperfections according to EN 10246-6 to acceptance level U2, sub-category C.

11.9.3 If option 16 (see 8.5.2.2) is specified the tubes shall be subjected to ultrasonic testing for the detection of the laminar imperfections at the tube ends according to EN 10246-17.

11.10 Material identification

Each tube shall be tested by an appropriate method to ensure that the correct grade is being supplied.

11.11 Retests, sorting and reprocessing

For retests, sorting reprocessing the requirements of EN 10021 shall apply.

12 Marking

12.1 Marking to be applied

Depending on the size of the tubes, the following marking shall either be applied on a label attached to the bundle or the box of tubes, or be marked indelibly on each tube at least at one end.

The marking shall include the following information:

- manufacturer's name or trade mark;
- dimension of the tubes;
- number of this part of EN 10216 and the steel name (or number) (see 5.2);
- cast number or a code number;
- test category;
- mark of the inspection representative;
- identification number (e.g. order or item number) which permits the correlation of the product or delivery unit to the related document,

and at the discretion of the manufacturer:

- symbol identifying the delivery condition (see Table 1).

Example of marking:

X – 168,3 X 4,5 – EN 10216-5 – 1.4301 – TC1 – HFD – Y – Z₁ – Z₂

where

- X is the manufacturer's mark;
- TC1 is the designation of the test category 1;
- HFD is the identification of the delivery condition;
- Y is the cast number or a code number;
- Z₁ is the mark of the inspection representative;
- Z₂ is the identification number.

12.2 Additional marking

Option 24: Additional marking, as agreed upon at the time of enquiry and order, shall be applied.

13 Handling and packaging

The tubes shall be protected from carbon steel strapping, which shall not come into contact with the tubes.

Option 25: If special protection is to be applied, this shall be specified at the time of enquiry and order

Annex A (informative)

Reference data of strength values for creep rupture of austenitic steels in the solution annealed condition

NOTE 1 The values given in Table A.1 are mean values of the scatter band considered until now.

NOTE 2 The strength values for creep rupture given up to the elevated temperatures listed in Table A.1 do not mean that the steels can be used in continuous duty up to these temperatures. The governing factor is the total stressing during operation. Where relevant, the oxidation conditions should also be taken into account.

Table A.1 - Creep rupture strength values (continued)

Steel designation		Temperature ^a	Creep rupture strength ^b in MPa for			
name	number	°C	10 000 h	100 000 h	200 000 h	250 000 h
X6CrNi18-10	1.4948	500	250	192	176	--
		510	239	182	166	--
		520	227	172	156	--
		530	215	162	146	--
		540	203	151	136	--
		550	191	140	125	--
		560	177	128	114	--
		570	165	117	104	--
		580	154	107	95	--
		590	143	98	86	--
		600	132	89	78	--
		610	122	81	70	--
		620	113	73	62	--
		630	104	65	55	--
		640	95	52	49	--
		650	87	58	43	--
		660	80	47	34	--
		670	73	42	38	--
		680	67	37	30	--
690	61	32	26	--		
700	55	28	22	--		
710	(45)	(22)	--	--		
720	(41)	(20)	--	--		
730	(38)	(18)	--	--		
740	(36)	(16)	--	--		
750	(34)	(15)	--	--		
X7CrNiTi18-10	1.4940	550	186	142	--	--
		575	162	110	--	--
		600	135	83	--	--
		625	111	65	--	--
		650	88	49	--	--
		675	67	36	--	--
		700	49	25	--	--
		725	38	19	--	--
		750	31	14	--	--
		775	24	11	--	--
800	20	8	--	--		

Steel designation		Temperature ^a	Creep rupture strength ^b in MPa for			
name	number	°C	10 000 h	100 000 h	200 000 h	250 000 h
X7CrNiNb18-10	1.4912	540	253	186 *	169 *	--
		550	237	172 *	156 *	--
		580	192	135 *	122 *	--
		600	166	115 *	102 *	--
		620	142	97 *	86 *	--
		650	112	74 *	64 *	--
		670	96	61	(51) *	--
		700	74		--	--
X6CrNiTiB18-10	1.4941	550	230	170	150	--
		560	220	150	130	--
		570	210	140	120	--
		580	190	120	110	--
		590	170	110	100	--
		600	160	100	90	--
		610	140	92	82	--
		620	130	84	74	--
		630	120	76	66	--
		640	110	68	60	--
		650	100	62	54	--
		660	90	56	48	--
		670	82	50	43	--
680	74	44	40	--		
690	66	39	38	--		
700	60	35	29	--		
X6CrNiMo17-13-2	1.4918	550	250	175	--	--
		560	235	164	--	--
		570	220	153	--	--
		580	205	142	--	--
		590	190	131	--	--
		600	175	120	--	--
		610	160	109	--	--
		620	147	98	--	--
		630	135	88	--	--
		640	123	78	--	--
		650	111	69	--	--
		660	100	60	--	--
		670	91	52	--	--
680	82	46	--	--		
690	73	40	--	--		
700	65	34	--	--		

EN 10216-5:2004 (E)

Steel designation		Temperature ^a	Creep rupture strength ^b in MPa for			
name	number	°C	10 000 h	100 000 h	200 000 h	250 000 h
X5NiCrAlTi31-20	1.4958	500	290	215	(196)	--
		510	279	205	(186)	--
		520	267	195	(176)	--
		530	254	184	(166)	--
		540	240	172	(155)	--
		550	225	160	(143)	--
		560	208	147	(130)	--
		570	190	133	(117)	--
		580	172	119	(105)	--
		590	155	106	(93)	--
		600	140	95	(83)	--
		610	128	85	(74)	--
		620	118	78	(68)	--
		630	109	72	(63)	--
		640	103	67	(59)	--
		650	97	63	(55)	--
660	91	59	(52)	--		
670	85	55	(48)	--		
680	80	52	(45)	--		
690	74	48	(41)	--		
700	69	44	(38)	--		
X5NiCrAlTi31-20	1.4958+RA ^c	500	315	258	(242)	--
		510	297	241	(225)	--
		520	280	224	(207)	--
		530	262	206	(190)	--
		540	243	189	(172)	--
		550	224	171	(155)	--
		560	204	153	(138)	--
		570	184	136	(122)	--
		580	165	119	(106)	--
		590	147	104	(92)	--
		600	131	90	(80)	--
		610	117	79	(70)	--
		620	106	70	(62)	--
		630	96	62	(55)	--
		640	87	56	(49)	--
		650	80	51	(44)	--
660	73	46	(40)	--		
670	67	42	(36)	--		
680	61	38	(33)	--		
690	55	34	(29)	--		
700	50	30	(26)	--		

Steel designation		Temperature ^a	Creep rupture strength ^b in MPa for			
name	number	°C	10 000 h	100 000 h	200 000 h	250 000 h
X8NiCrAl Ti32-21	1.4959	700	74,0	50,0	(44,0)	--
		710	68,0	45,0	(39,4)	--
		720	62,0	40,9	(35,5)	--
		730	56,0	37,4	(32,2)	--
		740	51,5	34,3	(29,3)	--
		750	47,5	31,6	(26,8)	--
		760	43,7	29,1	(24,6)	--
		770	40,5	27,0	(22,4)	--
		780	37,5	24,9	(20,7)	--
		790	35,0	23,1	(19,0)	--
		800	32,6	21,4	(17,5)	--
		810	30,4	19,8	(16,2)	--
		820	28,4	18,4	(15,1)	--
		830	26,5	17,0	(14,0)	--
		840	24,7	15,7	(13,0)	--
		850	23,0	14,4	(12,1)	--
		860	21,4	13,3	(11,2)	--
		870	19,9	12,2	(10,3)	--
		880	18,4	11,2	(9,5)	--
		890	17,0	10,3	(8,7)	--
		900	15,6	9,4	(8,0)	--
910	14,4	8,6	(7,3)	--		
920	13,2	7,8	(6,7)	--		
930	12,1	7,1	(6,2)	--		
940	11,1	6,4	(5,6)	--		
950	10,1	5,8	(5,0)	--		
960	9,2	5,3	(4,5)	--		
970	8,4	4,8	(4,1)	--		
980	7,7	4,4	(3,7)	--		
990	7,0	4,0	(1,3)	--		
1000	6,4	3,7	(1,0)	--		
X3CrNiMoBN17-13-3	1.4910	550	290	220	(200)	--
		560	272	202	(184)	--
		570	254	186	(166)	--
		580	237	170	(151)	--
		590	220	155	(137)	--
		600	205	141	(122)	--
		610	190	127	(113)	--
		620	174	114	(100)	--
		630	162	102	(91)	--
		640	148	92	(81)	--
		650	135	83	(73)	--
		660	122	75	(65)	--
		670	112	68	(58)	--
		680	102	61	(52)	--
		690	93	56	(46)	--
		700	84	52	(46)	---
		710	78	48	(39)	--
		720	71	45	(36)	--
		730	65	41	(34)	--
		740	58	37	(31)	--
750	52	34	(28)	--		
760	48	31	(26)	--		
770	44	28	(24)	--		
780	41	25	(21)	--		
790	37	22	(19)	--		
800	33	20	(17)	--		

EN 10216-5:2004 (E)

Steel designation		Temperature ^a	Creep rupture strength ^b in MPa for			
name	number		°C	10 000 h	100 000 h	200 000 h
X8CrNiNb16-13	1.4961	580	182	129	115	--
		590	170	119	105	--
		600	157	108	94	--
		610	145	98	85	--
		620	134	89	77	--
		630	124	80	69	--
		640	113	72	61	--
		650	103	64	53	--
		660	93	57	47	--
		670	84	50	41	--
		680	76	44	36	--
		690	70	39	31	--
		700	64	34	27	--
		710	59	30	25	--
		720	55	27	22	--
730	51	25	19	--		
740	47	22	17	--		
750	44	20	15	--		
X8CrNiMoVNb16-13	1.4988	580	299	209	180	--
		590	274	189	164	--
		600	250	172	147	--
		610	228	156	132	--
		620	207	139	117	--
		630	189	125	105	--
		640	173	111	93	--
650	157	98	82	--		
X8CrNiMoNb16-16	1.4981	580	270	186	162	--
		590	246	169	147	--
		600	225	152	132	--
		610	205	136	118	--
		620	186	122	103	--
		630	169	107	91	--
		640	152	94	80	--
		650	137	83	71	--
		660	124	75	63	--
		670	111	66	55	--
		680	100	59	49	--
		690	91	51	42	--
		700	83	44	35	--
		710	77	37	29	--
		720	70	31	24	--
730	64	26	20	--		
740	59	23	17	--		
750	54	20	15	--		

Steel designation		Temperature ^a	Creep rupture strength ^b in MPa for			
name	number	°C	10 000 h	100 000 h	200 000 h	250 000 h
X10CrNiMoMnNbVB 15-10-1	1.4982	600	241	199	183	177
		610	231	185	165	158
		620	221	167	143	134
		630	210	147	118	109 *
		640	198	122	97	90 *
		650	184	100	82	78 *
		660	167	84	72	69 *
		670	147	74	64	62 *
		680	124	66	58	56 *
		690	102	59	52	51 *
		700	86	54	48	46 *
		710	75	49	43	42 *
		720	67	45	39	37 *
		730	61	40 *	35 *	--
		740	55	36 *	--	--
		750	51	30 *	--	--
760	46	--	--	--		
770	42	--	--	--		
780	38	--	--	--		

^a For cooling conditions see Table 7.

^b Values in parantheses involve time and/or stress extrapolation; values with asterisk involve time extrapolation.

^c +RA = recrystallizing annealed condition.

Annex ZA (informative)

Clauses of this part of EN 10216 addressing essential safety requirements of the EU Directive 97/23/EC

This part of EN 10216 has been prepared under a mandate given to CEN by the European Commission and the European Free Trade Association to provide a means of conforming to Essential Requirements of the New Approach Directive No. 97/23/EC on Pressure Equipment.

Warning: Other requirements and other EU Directives may be applicable to the product(s) falling within the scope of this standard.

Once this standard is cited in the Official Journal of the European Union under that Directive and has been implemented as a national standard in at least one Member State, compliance with the clauses of this standard given in Table ZA.1 confers, within the limits of the scope of this standard, a presumption of conformity with the corresponding Essential Requirements of that Directive and associated EFTA regulations.

Table ZA.1 – Correspondence between this part of EN 10216 and the EU Directive 97/23/EC Annex I

Clauses/sub-clauses of this part of EN 10216	Essential Requirements (ERs) of the EU Directive 97/23/EC	Qualifying remarks/ Notes
8.3 and 8.4	Annex I, 4.1 a	Appropriate material properties
7.2 and 8.5	Annex I, 4.1 d	Suitable for the processing procedures
9 and 10	Annex I, 4.3	Documentation

Bibliography

EN 473, *Non destructive testing - Qualification and certification of NDT personnel - General principles.*